



US006588208B1

(12) **United States Patent**
Clements

(10) **Patent No.:** **US 6,588,208 B1**
(45) **Date of Patent:** **Jul. 8, 2003**

- (54) **WIRELESS TECHNIQUE FOR MICROACTIVATION**
- (75) Inventor: **Ken Clements**, Los Gatos, CA (US)
- (73) Assignees: **Technology Innovations, LLC**, West Henrietta, NY (US); **Ken Clements**, Los Gatos, CA (US)
- (*) Notice: Subject to any disclaimer, the term of this patent is extended or adjusted under 35 U.S.C. 154(b) by 0 days.

5,061,914 A	10/1991	Busch et al.	
5,226,619 A *	7/1993	Alger	246/219
5,325,880 A *	7/1994	Johnson et al.	137/1
5,619,177 A *	4/1997	Johnson et al.	337/140
5,903,099 A	5/1999	Johnson et al.	

* cited by examiner

Primary Examiner—Hoang Nguyen
(74) *Attorney, Agent, or Firm*—Greenwald & Basch LLP; Duane C. Basch

- (21) Appl. No.: **10/058,887**
- (22) Filed: **Jan. 28, 2002**

Related U.S. Application Data

- (60) Provisional application No. 60/264,741, filed on Jan. 29, 2001.
- (51) **Int. Cl.**⁷ **F01B 29/10**
- (52) **U.S. Cl.** **60/527; 60/528**
- (58) **Field of Search** 60/527, 528

(56) **References Cited**

U.S. PATENT DOCUMENTS

4,864,824 A 9/1989 Gabriel et al.

(57) **ABSTRACT**

The present invention is a method and apparatus for achieving high work output per unit volume in micro-robotic actuators, and in particular TiNi actuators. Such actuators are attractive as a means of powering nano-robotic movement, and are being developed for manipulation of structures at near the molecular scale. In these very small devices (one micron scale), one means of delivery of energy is by electron beams. Movement of mechanical structures a few microns in extent has been demonstrated in a scanning electron microscope. Results of these and subsequent experiments will be described, with a description of potential structures for fabricating moving a microscopic x-y stage.

12 Claims, 2 Drawing Sheets

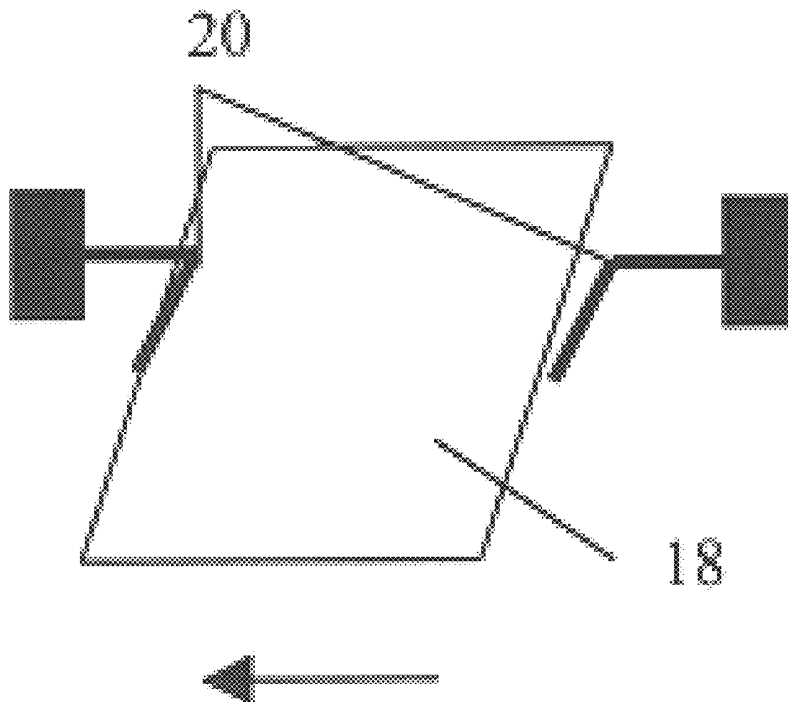

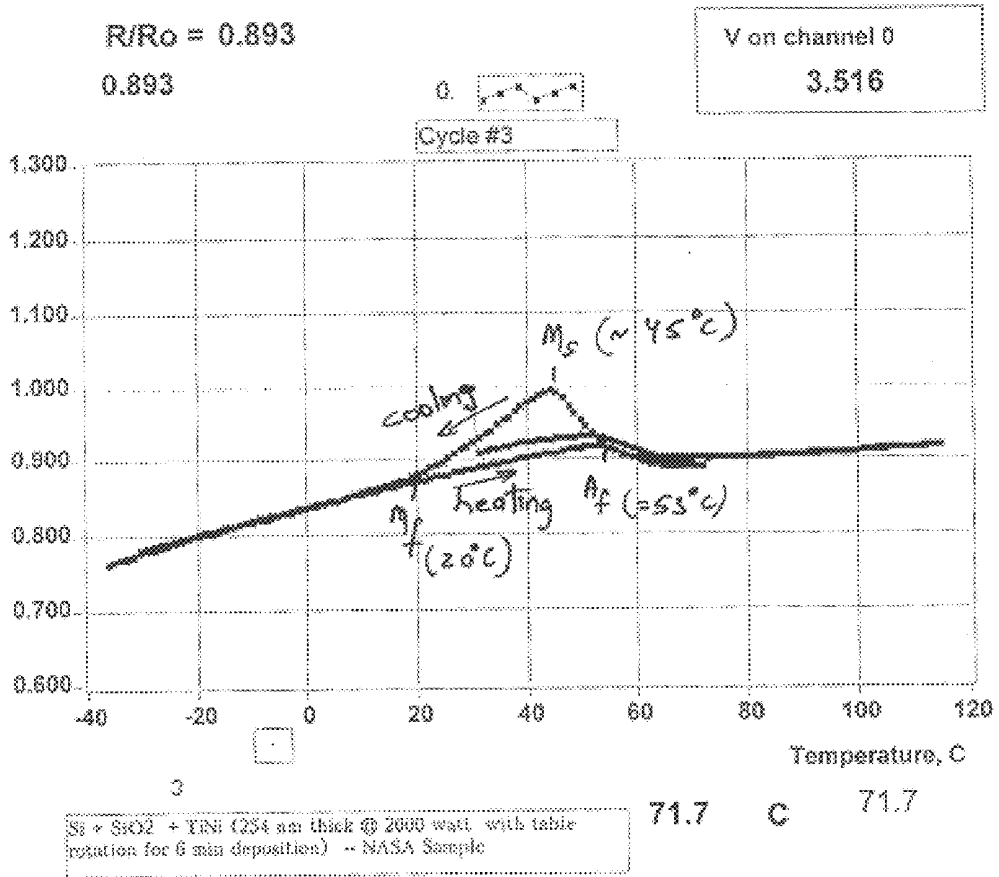

Figure 1

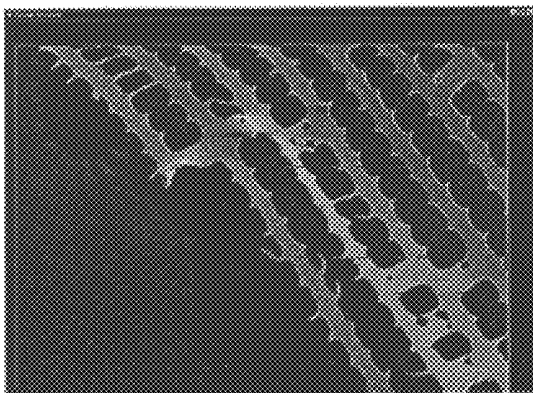

Figure 2

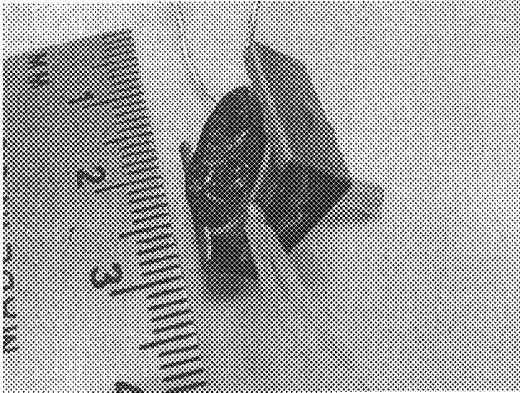

Figure 3

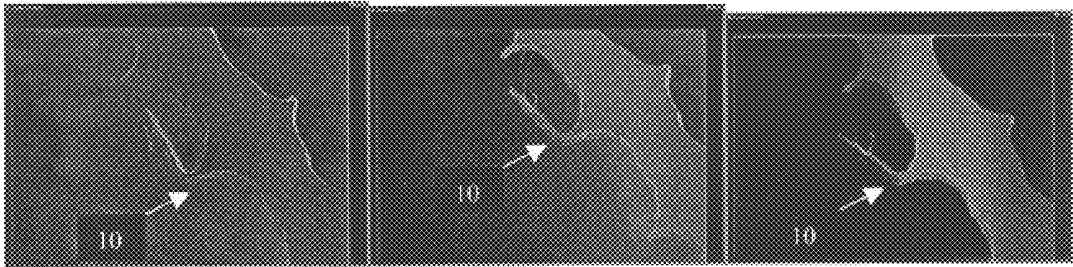

Fig. 4a)

Fig. 4b)

Fig. 4c)

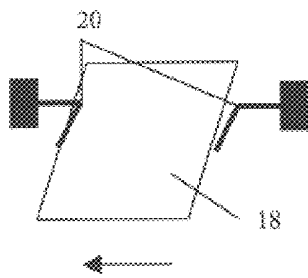

Figure 5a

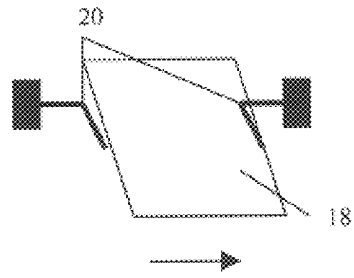

Figure 5b

WIRELESS TECHNIQUE FOR MICROACTIVATION

This application claims the benefit of Provisional Application No. 60/264,741, filed Jan. 29, 2001.

CROSS REFERENCE

U.S. Provisional Application for Patent, Ser. No. 60/264,741, filed Jan. 29, 2001, is hereby incorporated by reference for its teachings.

The following related publications are also hereby incorporated by reference for their teachings:

K. Eric Drexler, *Engines of Creation: the coming era of nanotechnology*, Anchor Doubleday, 1986;

K. Eric Drexler, *Nanosystems, Molecular Machinery, Manufacturing, and Computation*, John Wiley & Sons, Inc., 1992;

James R. von Ehr, Zyvex "the first nanotechnology development company", <http://www.zyvex.com>;

MF Yu, M. J. Dyer, G. D. Skidmore, H. W. Rohrs, XK Lu, K. D. Ausman, J. R. Von Ehr, R. S. Ruoff, 3 Dimensional Manipulation of Carbon Nanotubes under a Scanning Electron Microscope, Sixth Foresight Conference 1998;

A. D. Johnson, "Vacuum-Deposited TiNi Shape memory Film: Characterization and Applications in Micro-Devices," *J. Micromech. Microeng.* 1(1991) 34-41;

P. Krulevitch, A. P. Lee, P. B. Ramsey, J. C. Trevino, J. Hamilton, M. A. Northrup, "Thin film Shape Memory Alloy Microactuators," *J. MEMS*, vol. 5, No. 4, December 1996 (showing that SMA has the highest work output per unit volume of any actuating technology); and

Deepak Srivastava, NASA Ames research Center, Moffett Field, 650 604 3468 deepak@nasa.gov; private communication to Vikas Galhotra at TiNi Alloy Company.

This invention relates generally to production and operation of microactuators by focused beam energy, and more particularly to a wireless technique for both control and energy, as well as the return path for observation and data.

BACKGROUND AND SUMMARY OF THE INVENTION

In 1982 K. Eric Drexler introduced the idea of assemblers of molecular size in his book "Engines of Creation" (cited above). Nanotechnology is the subject of at least one international conference, and one commercial venture has been organized and funded to invest research and planning in this technology. Although commercial realization of nanotechnology may be years away, there is strong indication that research following the human genome project, and particularly the study of protein structure and function, will require tools to manipulate components of the cell. Development of these tools is a demanding, exciting, and challenging research subject.

Miniaturization of mechanical devices is evolving toward nanometer scale, requiring handling and assembly of objects as small as a few nanometers. Manipulation of samples and specimens smaller than a few microns in size demands a technology that, at present, does not exist. Assemblers are needed that can grip collections of molecules, releasing them from their present location, lifting, rotating, and forcefully placing them in a new environment.

Existing micropositioners do not provide the requisite flexibility of motion for assembly tasks that are contem-

plated. Forceful shape memory alloy actuators can be scaled to micron size. These devices are thermally powered and so require a source of heat energy: this heat may be supplied by conduction, joule heating, infrared light, or other means. The present invention contemplates the use of a scanning electron microscope beam to provide heat energy to energize thermal actuators. Prototype actuators are fabricated by sputter deposition of titanium-nickel thin film, photolithographic patterning, and chemical milling. A scanning electron beam is positioned to produce local heating, and to observe the resulting motion.

Atomic force microscopy can be used to move individual atoms but not to grip larger objects with enough force to hold against local forces. In recent investigations of the properties of carbon nanotubes, piezoelectric stepper motors have been used to manipulate structures orders of magnitude smaller than the drivers (see MF Yu et al. in "3 Dimensional Manipulation of Carbon Nanotubes under a Scanning Electron Microscope"). Manipulation of objects this small would be improved if the end-effectors were not much larger than the objects they control. In analogy to the shoulder-wrist-finger arrangement of the human hand, gross positioning should be managed by actuators of macroscopic size, and fine control by end-effectors of much smaller size.

The force of actuation should be produced as close as possible to the point of application. This implies that manipulation of sub-micron size objects requires micron-size actuators. Conventional actuators (electromagnetic, piezoelectric) do not scale well to micron size. A promising form of actuation is heat-actuated devices, particularly shape memory actuators. Photolithography provides means of fabricating devices of sub-micron size. Miniature shape memory alloy (SMA) actuators rely on joule heating to cause the phase change. In the sub-micron range it is difficult to make electrical connection, especially on devices that move. To solve this problem, the present invention focuses on the actuation of sub-micron scale shape memory alloy devices by electron-beam excitation.

The present invention is directed to the operation of microactuators by focused beam energy. Whereas microactuators now require wires or tubes attached to get the energy and control signals down to them, this invention discloses a wireless technique for both control and energy, as well as the return path for observation and data.

Current devices are fabricated as small as a few hundred microns using conventional microlithography. Shrinking this technology to sub-micron dimensions has raised at least two questions: (i) Will the shape memory property be preserved when the dimensions are as small or smaller than the crystal domains? And (ii) How can such small objects (sub-micron) be selectively heated to produce actuation? The present invention, based upon research conducted to answer such questions, provides preliminary proof-of-concept.

In accordance with the present invention, there is provided a method for driving a shape memory alloy actuator, including the steps of: pre-straining a shape memory alloy in its low-temperature state; and subsequently, heating the shape memory alloy above its phase transformation temperature using a focused beam.

One aspect of the invention is based on the discovery of techniques for achieving high work output per unit volume in micro-robotic actuators, and in particular TiNi and similar actuators. Such actuators are attractive as a means of powering nano-robotic movement, and are suitable for manipulation of structures at or near the molecular scale. In these

very small devices (one micron scale), one means of delivery of energy is by electron beams. Movement of mechanical structures a few microns in extent has been demonstrated in a scanning electron microscope. Results of these and subsequent experiments will be described, with a description of potential structures for fabricating moving a microscopic x-y stage.

BRIEF DESCRIPTION OF THE DRAWINGS

FIG. 1 is a graph of resistivity versus temperature for an exemplary TiNi film sputter-deposited on silicon oxide in accordance with an aspect of the present invention;

FIG. 2 is a scanning electron beam image of TiNi film with fenestrations;

FIG. 3 is a heated sample holder for a scanning electron microscope in accordance with an aspect of the present invention;

FIGS. 4a-4c are a sequence of images from the SEM showing the results of heating the TiNi specimen by SEM electron beam; and

FIGS. 5a and 5b are illustrative schematics of a single-direction platform moved by microactuators in accordance with an aspect of the present invention.

The present invention will be described in connection with a preferred embodiment, however, it will be understood that there is no intent to limit the invention to the embodiment described. On the contrary, the intent is to cover all alternatives, modifications, and equivalents as may be included within the spirit and scope of the invention as defined by the appended claims.

DESCRIPTION OF THE PREFERRED EMBODIMENT

For a general understanding of the present invention, reference is made to the drawings. In the drawings, like reference numerals have been used throughout to designate identical elements.

As depicted by information in the associated figures, the present invention is directed to the operation of microactuators by focused beam energy. As depicted in the graph of FIG. 1, memory property may be preserved when the dimensions of a device are as small or smaller than the crystal domains. For example, a film approximately 100 nanometers (nm) (about 200 atomic layers) thick was shown to undergo a phase transformation as indicated by a change in resistivity. The change in slope and hysteresis loop are typical for TiNi shape memory alloy (SMA).

As noted herein, a scanning electron microscope electron beam (e-beam) may be used to provide the heat energy, and beam steering can bring a spot of energy a fraction of a micron in diameter to bear on a sample. Therefore, the questions of how much power must be delivered to the sample, and whether the beam can provide this much energy in a short enough time to effect a shape change were addressed.

The estimated energy required to actuate a TiNi specimen $4 \times 10 \times 100$ microns by heating it from the room temperature to the transition point is about 1.3×10^{-5} joules ($DT = -80$ C, $DH = -25$ J/gm, $C_p = -0.3$ J/gm $^\circ$ C., density = 6.4 gm/cm 3). The power available from the electron beam is 2×10^{-3} watt (for accelerating voltage ~ 20 KV and beam current $\sim 10-7$ A) and the estimated heating time is $\sim 6 \times 10^{-3}$ sec.

Demonstration of shape recovery requires that the specimen be pre-strained (stretched, compressed, or bent) while it is in its low-temperature state and then heated above the

phase transformation temperature. The sample used was a fragment of TiNi film 4 micrometers thick deposited on silicon oxide, and patterned with fenestrations about 40 microns in diameter, and removed from the substrate. This film was further etched to diminish the width and thickness of the web elements. The resulting web was torn apart, producing small protrusions about 1-2 micron wide and 20 microns long. Referring to FIG. 2, one such structure is depicted in the micrograph. Some of these were bent during tearing, others were deformed manually using a micromanipulator.

Once the structures were isolated, the specimen was placed on a heated pedestal in an ISI-SS60 scanning electron microscope. The pedestal was equipped with a heater and thermocouple so that the base temperature of the structure could be controlled and measured. An exemplary fixture is depicted in FIG. 3 against a size reference. Fluke instruments were used to record temperature and current through the heater, and an IRF 640 field-effect transistor, with a variable gate voltage, was used to control the current through the heater to vary the temperature of the substrate.

Subsequently, the chamber was evacuated and the e-beam was started. A picture was obtained at 1.5 kx magnification. The sample holder was heated with resistance heater to a temperature above ambient of approximately 40° C. and approximately 10° C. below the transition temperature around $45-50^\circ$ C. of the TiNi. This was to enable the electron beam to bring the temperature through a relatively small temperature change to effect the phase transformation. The beam was centered approximately on the bent portion of the microbeam as indicated by reference arrow 10. It should be further appreciated that the amount of pre-heating energy applied influences the amount of power that must be applied by the focused beam—the lower the pre-heat temperature of the shape memory alloy, the more energy that must be applied by the beam.

The SEM beam aperture was opened to impart the maximum current to the specimen, using spot mode, and current in the e-beam was increased. Typical current used was in the range of 70 to 100 nano-amperes measured with a Kiethley picoammeter connected between the sample and ground potential. This current was applied to the sample for a time between 2 and 10 seconds, although other exposure times may be suitable. After exposure, the beam current was reduced and further pictures taken.

The resultant movement of the structure are shown in FIGS. 4a through 4c. In particular, image FIG. 4a shows the sample previous to heating. Images 4b and 4c, in turn, show the progressive actuation as successive parts of the device were heated by the electron beam. Approximately thirty degrees of recovery was achieved, although other levels may be possible depending upon the structure characteristics. Accordingly, the lever achieved in the experimental design is about 2 microns in diameter and 20 microns long.

As a result of the initial experiments, the micro-cantilever moving about thirty degrees from its original position was not due to thermal expansion as it did not reverse when the temperature was reduced. Thus, actuation of a micro-scale device by scanning electron beam was demonstrated, showing that the e-beam can provide enough energy to cause the phase transformation (and resultant movement) under controlled conditions.

Using such information, the present invention is directed toward a number of alternative embodiments. One such embodiment, depicted in FIGS. 5a and 5b, contemplates construction of a platform 18 and providing molecular and

5

nano-level x-y motion using pairs of opposed bending cantilevers 20, so that partial actuation of one cantilever pushes the platform in the direction of the arrow while pre-straining the opposing cantilever. Similarly, it is believed that larger-scale, translational motion can be achieved with multiple actuators operating in sequence against a ratcheting or similar advancement mechanism.

In the electron microscope embodiment described herein, it is further contemplated as part of the invention, that the normal beam is used for both causing and observing movement of the memory alloy segment or structure. Moreover, a software or similar feedback loop may be implemented, perhaps providing wireless control of microrobotic systems. Analogous actions can be done in the optical and ultrasonic embodiments described below.

In an alternative to the e-beam embodiment described above, it is also contemplated that aspects of the present invention may be implemented using laser energy in an optical microscope. It will be appreciated by those skilled in the art that the concept is the same in both cases; a beam of energy focused on a shaped memory alloy segment will produce local heating of the segment, giving rise to movement.

In accordance with the embodiments described herein, SMA microactuators may be produced to provide the "muscles" of tiny robots that are fabricated by MEMS technology on silicon wafers. It will be further appreciated that such structures may be employed for fabricating other nanotechnology devices and elements, and particularly for moving a microscopic x-y stage. However, this invention is also applicable to nanotechnology where the nanoactuators are large molecules that are undergoing shape transformations as a result of interactions with focused beam energy such as photons, particle beams (such as electrons), or phonons (ultrasound).

In recapitulation, the present invention is a method and apparatus for the production and operation of microactuators by focused beam energy, and more particularly to a wireless technique for both control and energy, as well as the return path for observation and data.

It is, therefore, apparent that there has been provided, in accordance with the present invention, a method and apparatus for the creation and application of microactuators. While this invention has been described in conjunction with preferred embodiments thereof, it is evident that many alternatives, modifications, and variations will be apparent to those skilled in the art. Accordingly, it is intended to embrace all such alternatives, modifications and variations that fall within the spirit is and broad scope of the appended claims.

What is claimed is:

1. A method for driving a cantilevered shape memory actuator, including the steps of:

mechanically pre-straining, using an externally applied force, a cantilevered shape memory alloy element in its low-temperature state to produce a cantilevered shape memory actuator; and

subsequently, heating the cantilevered shape memory actuator above its phase transformation temperature using a focused beam directed to the cantilevered shape memory actuator so as to cause a first portion of the shape memory alloy actuator to move relative to a second portion.

2. The method of claim 1, wherein the focused beam is a particle (electron) beam.

3. The method of claim 1, wherein the focused beam is a photon beam.

6

4. The method of claim 1, wherein the focused beam is a phonon beam.

5. The method of claim 2, where an electron beam is applied while the shape memory actuator is located within a scanning microscope.

6. A method for driving a shape memory actuator, including the steps of:

pre-straining a shape memory alloy in its low-temperature state to produce a shape memory actuator;

applying a thermal pre-heating bias to the shape memory actuator; and

subsequently, heating the shape memory actuator above its phase transformation temperature using a focused beam so as to cause a first portion of the shape memory alloy actuator to move relative to a second portion, wherein the thermal pre-heating bias reduces the amount of energy needed for application by the focused beam.

7. An apparatus for driving a shape memory actuator, including:

a shape memory actuator having at least one protrusion extending therefrom;

means for pre-straining said shape memory actuator, by displacing the protrusion in its low-temperature state;

a scanning microscope for receiving the pre-strained shape memory actuator therein; and

subsequently, heating the shape memory alloy actuator using a focused beam directed at a point near the displacement, thereby causing the temperature to rise above its phase transformation temperature and the shape memory alloy actuator to move as it returns to its earlier position.

8. The method of claim 1, wherein the cantilevered shape memory actuator comprises a protrusion having a width of less than about 2 microns and length of about 20 microns extending from a flexible anchor point at which the mechanical pre-straining step is induced.

9. The method of claim 8, wherein the focused beam is directed at the anchor point of the cantilevered shape memory actuator.

10. The method of claim 8, wherein the focused beam is directed at the anchor point of the cantilevered shape memory actuator for a period of at least about 2 seconds and not greater than about 10 seconds.

11. The apparatus of claim 7, wherein the first shape memory actuator is in the form of a cantilever having a protrusion extending from a flexible anchor point, wherein the protrusion is bent with respect to the anchor point and where the apparatus further comprises:

a second shape memory actuator also having a protrusion extending from a flexible anchor point, wherein the protrusion is placed in a position opposite that of the first shape memory actuator and the protrusion on the second shape memory actuator is not bent with respect to its anchor point;

a platform disposed between the first and second shape memory actuators, such that when the first shape memory actuator is heated at the anchor point, it advances the platform in the direction of the second shape memory actuator causing the second shape memory actuator protrusion to become bent and thereby prestrain the second shape memory actuator.

12. The apparatus of claim 7 wherein the shape memory actuator is formed from a material film having a thickness of about 100 nanometers.

* * * * *